

# IN-TRUST PROPERTIES SALE

CENTRAL APPRAISAL DISTRICT OF TAYLOR COUNTY  
TAYLOR COUNTY, TEXAS

**Jury Assembly Room / First Floor of Taylor County Courthouse / 300 Oak St / Abilene, Texas**

**December 1, 2020 ----- 10:00 A.M.**

*Due to security measures at the courthouse, please arrive 30 minutes prior to the time of the sale to go thru the security equipment.*

## **GENERAL INFORMATION REGARDING THE TAX SALE**

**The following is important information regarding the property to be offered for sale. You must carefully read this information and evaluate these facts in light of your anticipated use of the property.**

**SOCIAL DISTANCING WILL BE PRACTICED AND A MASK/FACE COVERING WILL BE REQUIRED**

**PLEASE PRINT AND BRING THE COMPLETED BIDDER'S ACKNOWLEDGEMENT FORM TO THE SALE**

1. The property will be offered at public auction and the highest bid, based on oral bids will be submitted to the taxing units for approval. The rules covering auctions generally will apply. **Successful bidders must remit payment in full by 5:00 p.m. on the day of the sale by cash or check payable to the Central Appraisal District at 1534 So. Treadaway, Abilene, Texas.** A \$38.00 fee for recording your deed will be added to each bid.

2. The amount of the opening bid is set out below each tract, and the bidding must start at that figure or higher, and sums less than the given figure cannot be accepted.

3. This sale is based on the judicial foreclosure of the statutory property tax liens on the property.

4. Liens on the property due to municipal liens including, but not limited to mowing, demolition, & etc., may or may not be released. Check with the County Clerk's Office and/or the City Hall where the property is located for this information.

**5. Purchasers at this sale will receive a deed which is without warranty, express or implied.**

**6. All property purchased at this sale may be subject to a statutory right of redemption.** This redemption period began on the date the Sheriff's deed was filed for record in the County Clerk's office. Purchasers have the right of possession during the redemption period. There is a two year right of redemption for homestead property and property appraised as agricultural land. There is a 180 days right of redemption for all other property.

7. Anyone having a legal interest in the property at the time of this sale may redeem the property from the purchaser during the redemption period. The redemption price is set by the Property Tax Code.

8. Since purchasers will have a deed without warranty, a policy of title insurance may be difficult to obtain.

9. It will be necessary for the bidders to satisfy themselves concerning location of the property on the ground prior to the sale. Maps and plats of these properties are on file in the office of the County Clerk and all papers in the lawsuit(s) on which this sale is based are on file in the office of the District Clerk. **The approximate property address reflected herein is the address on the tax records and may or may not be completely accurate.**

10. A bidder at the sale must be registered at the time the sale begins with the person conducting the sale.

*If you have questions or need additional information, you may contact our Abilene office at 325-672-4870 or the Central Appraisal District of Taylor County. From the taylor-cad.org website buyers may access the Abilene Map Server to locate the properties.*

# TAYLOR COUNTY IN-TRUST PROPERTIES SALE

**December 1, 2020**

**PROPERTY TO BE SOLD**

|   |                |  |  |            |
|---|----------------|--|--|------------|
| 1 | <b>11482-D</b> | Central Appraisal District of Taylor County v John Sellers et al   | <p>Manufactured Home, Label # TXS0571747, Serial # LM7335, 14' x 76', Taylor County, Texas</p> <p style="text-align: center;"><b>Account #63514</b></p> <p style="text-align: center;">Judgment Through Tax Year: 2018</p> <p style="text-align: center;"><b>APPROXIMATE ADDRESS: 5174 TWYLIGHT TR</b></p>   | \$900.00   |
| 2 | <b>11556-D</b> | Central Appraisal District of Taylor County v Margaret Griffin     | <p>14' x 46', Festival Ltd., Manufactured Home, Label #TEX0559601, Serial #TXFLS12A74197FD11, Taylor County, Texas</p> <p style="text-align: center;"><b>Account #88856</b></p> <p style="text-align: center;">Judgment Through Tax Year: 2018</p> <p style="text-align: center;"><b>APPROXIMATE ADDRESS:<br/>210 DYESS FARMS LN</b></p>   | \$900.00   |
| 3 | <b>11787-D</b> | Central Appraisal District of Taylor County v Roberto Torres et al | <p>a portion of the J.F. Northington's Preemption Survey, City of Abilene, and as assessed on the roll, Taylor County, Texas (Vol. 3302, Page 228, Official Public Records)</p> <p style="text-align: center;"><b>Account #52989</b></p> <p style="text-align: center;">Judgment Through Tax Year: 2019</p> <p style="text-align: center;"><b>APPROXIMATE ADDRESS: 1281 SYCAMORE</b></p> | \$2,500.00 |
| 4 | <b>50450-A</b> | Central Appraisal District of Taylor County v M. W. Smith et al    | <p>the North 47.8' of Lot 14, and all of Lots 15 and 16, Block 6, North Park Addition, City of Abilene, Taylor County, Texas (Vol. 535, Page 505, Deed Records)</p> <p style="text-align: center;"><b>Account #62331</b></p> <p style="text-align: center;">Judgment Through Tax Year: 2019</p> <p style="text-align: center;"><b>APPROXIMATE ADDRESS: VOGEL AVENUE</b></p>              | \$1,900.00 |

|   |         |   |   |            |
|---|---------|---|---|------------|
| 5 | 27841-B | Central Appraisal District of Taylor County v Brima L. Kanneh et al | <p>Lot 5, Block 15, Section 1, Wyndrock Addition, City of Abilene, Taylor County, Texas (Document #2010-00016066, Official Public Records)</p> <p><b>Account #63108</b></p> <p>Judgment Through Tax Year: 2019</p> <p><b>APPROXIMATE ADDRESS: 4701 CLOVER LANE</b></p>                          | \$2,500.00 |
| 6 | 27869-B | Central Appraisal District of Taylor County v David Junior Moore    | <p>Lots 2 and 3, Angus Subdivision of and a part of Block 1, College Addition, City of Merkel, Taylor County, Texas (Document #2010-00016452, Official Public Records)</p> <p><b>Account #17129</b></p> <p>Judgment Through Tax Year: 2019</p> <p><b>APPROXIMATE ADDRESS: WALNUT-MERKEL</b></p> | \$900.00   |
| 7 | 27869-B | Central Appraisal District of Taylor County v David Junior Moore    | <p>Lots 6 and 7, Block P, Bettes Heights Addition, City of Merkel, Taylor County, Texas (Document #2012-00011822, Official Public Records)</p> <p><b>Account #63217</b></p> <p>Judgment Through Tax Year: 2019</p> <p><b>APPROXIMATE ADDRESS: N/A, MERKEL</b></p>                               | \$700.00   |
| 8 | 27940-B | Central Appraisal District of Taylor County v Ronald Gibson         | <p>Lot 5, Block 4, Bowyer Addition, City of Abilene, Taylor County, Texas (Instrument #2017-00019116, Official Public Records)</p> <p><b>Account #49791</b></p> <p>Judgment Through Tax Year: 2019</p> <p><b>APPROXIMATE ADDRESS: 2234 PALM</b></p>   | \$3,654.00 |

**DELINQUENT TAX SALE - DECEMBER 1, 2020  
CENTRAL APPRAISAL DISTRICT OF TAYLOR COUNTY**

**SOCIAL DISTANCING WILL BE PRACTICED AND A MASK/FACE COVERING WILL BE  
REQUIRED**

**\*\*PLEASE PRINT AND BRING THE COMPLETED BIDDER'S ACKNOWLEDGEMENT FORM TO THE SALE\*\***

You must **READ THE FOLLOWING IMPORTANT INFORMATION** regarding the property to be offered for sale.

1. Prior to the beginning of the tax sale, a person intending to bid is required to register with the person conducting the sale and present a valid Driver's License or identification card issued by a State agency or the United States government. The grantee named in the deed must be the same person who was the successful bidder. (Section 34.015 Texas Tax Code.)
2. The property will be sold at public auction for cash to the highest bidder, based on oral bids. **Successful bidders must remit payment in full by 5:00 p.m. on the day of the sale by cash or check payable to the Central Appraisal District at 1534 So. Treadaway, Abilene, Texas.** Any bidder who fails to make payment shall be held liable for twenty percent of the value of the property plus costs incurred as a result of the bidder's default pursuant to Rule 652 of the Texas Rules of Civil Procedure.
3. The minimum bid amount is set out beside each tract. The bidding must start at the minimum bid amount. The minimum bid amount includes taxes which were delinquent at the date of judgment and purchasers will be required to pay all taxes which accrued subsequent to the date of judgment.
4. Purchasers at this tax foreclosure sale will receive an ordinary type of Sheriff's Deed which is WITHOUT WARRANTY, express or implied. Title to property is NOT guaranteed. A policy of title insurance may be difficult to obtain.
5. All property purchased at this sale is subject to a statutory right of redemption. This redemption period commences to run from the date the purchaser's deed is filed for record in the deed records. There is a two year right of redemption for homestead property and property appraised as agricultural land. There is a 180 day right of redemption for all other property. Purchasers have a right of possession beginning twenty days after the purchaser's deed is filed in the deed records (Sec. 33.51 Tax Code).
6. Anyone having an ownership interest in the property at the time of the sale may redeem the property from the purchaser during the redemption period. The redemption price is set by the Texas Tax Code as follows: purchase amount, deed recording fee, taxes paid by purchaser after the tax sale, and costs expended on the property, plus a redemption premium of 25 percent of the aggregate total during the first year or 50 percent of the aggregate total during the second year. "Costs" are only the reasonable expenses incurred by the purchaser for the maintenance, preservation and safekeeping of the property. Do NOT make unnecessary repairs or renovations during the redemption period.
7. Property is sold by legal description. Bidders must satisfy themselves concerning the location and condition of the property on the ground, including the existence of improvements on the property, prior to this tax sale. Property is sold "AS IS" with all faults. All sales are final. There are no refunds. Deeds, maps and plats of the properties are in the County Clerk's office or the Appraisal District. Lawsuit files on which this sale is based are in the office of the District Clerk. Any property address reflected on the bid sheet is the address on the tax records and may not be accurate.
8. Property purchased at this tax sale may be subject to liens for demolition, mowing, or maintenance fees due to the City or Property Owners Association in which the property is located.

If you have any questions, you may contact our office in Abilene at (325) 672-4870.

**BIDDER'S ACKNOWLEDGEMENT**

**I DO HEREBY ACKNOWLEDGE THAT I HAVE READ THE FOREGOING INFORMATION.** I understand these rules and that it is my responsibility to evaluate these facts in light of my intended use of the property and do hereby register to bid on these properties. I further acknowledge that the "NAME OF GRANTEE" PRINTED BELOW IS EXACTLY AS IT WILL APPEAR ON THE DEED in the event I am a successful bidder on any property and that the deed will be mailed to the address shown below.

BIDDER REGISTRATION NUMBER \_\_\_\_\_

PRINTED NAME OF BIDDER(S): \_\_\_\_\_

BIDDER'S ADDRESS: \_\_\_\_\_ CITY: \_\_\_\_\_ ZIP: \_\_\_\_\_

BIDDER'S HOME/OFFICE TELEPHONE: \_\_\_\_\_ CELL PHONE: \_\_\_\_\_

EMAIL: \_\_\_\_\_

BIDDER'S SIGNATURE: \_\_\_\_\_

BIDDER'S SIGNATURE: \_\_\_\_\_

# Delinquent Sales Tax

## PropID:63514 MH ONLY

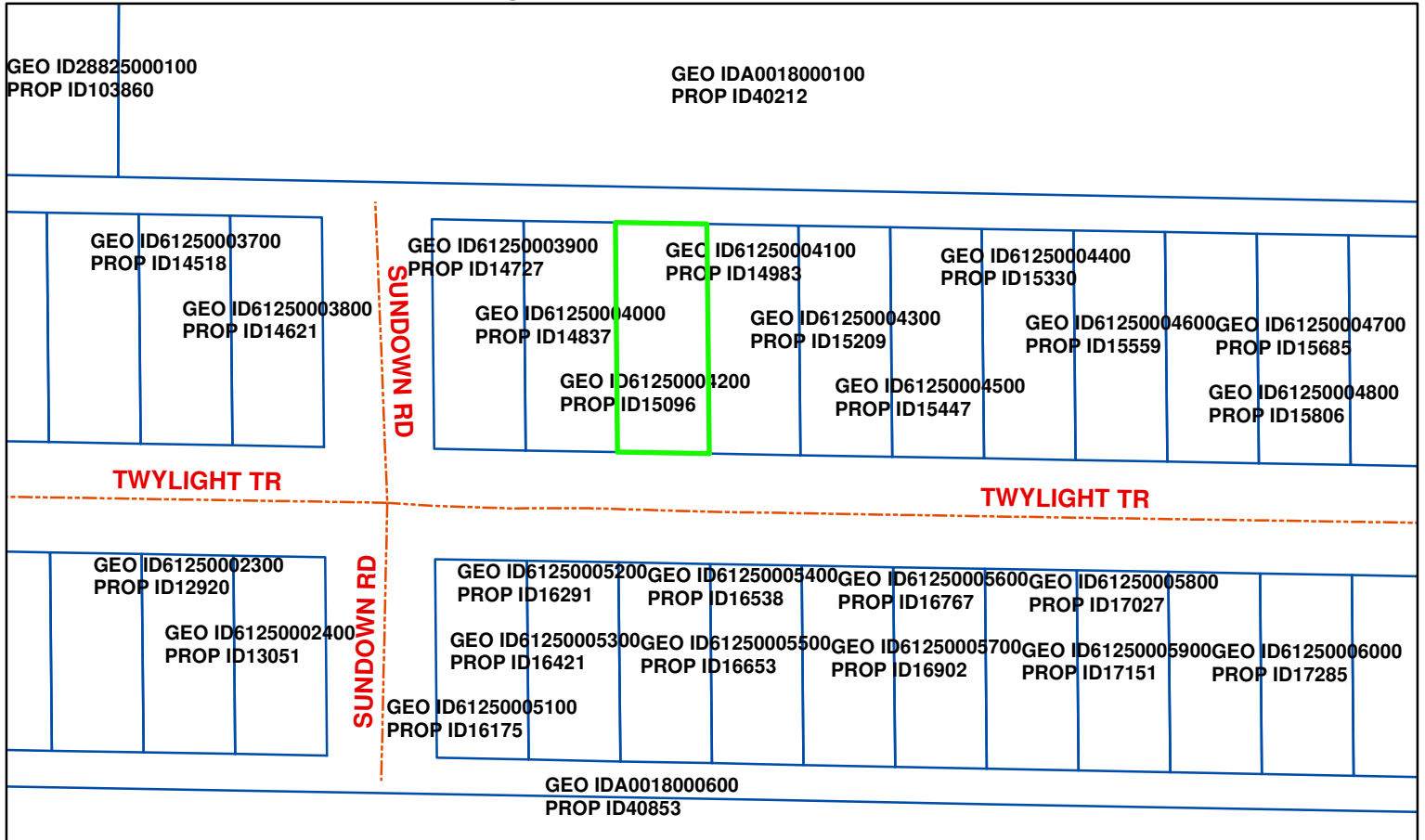

## PropID:88856 MH ONLY

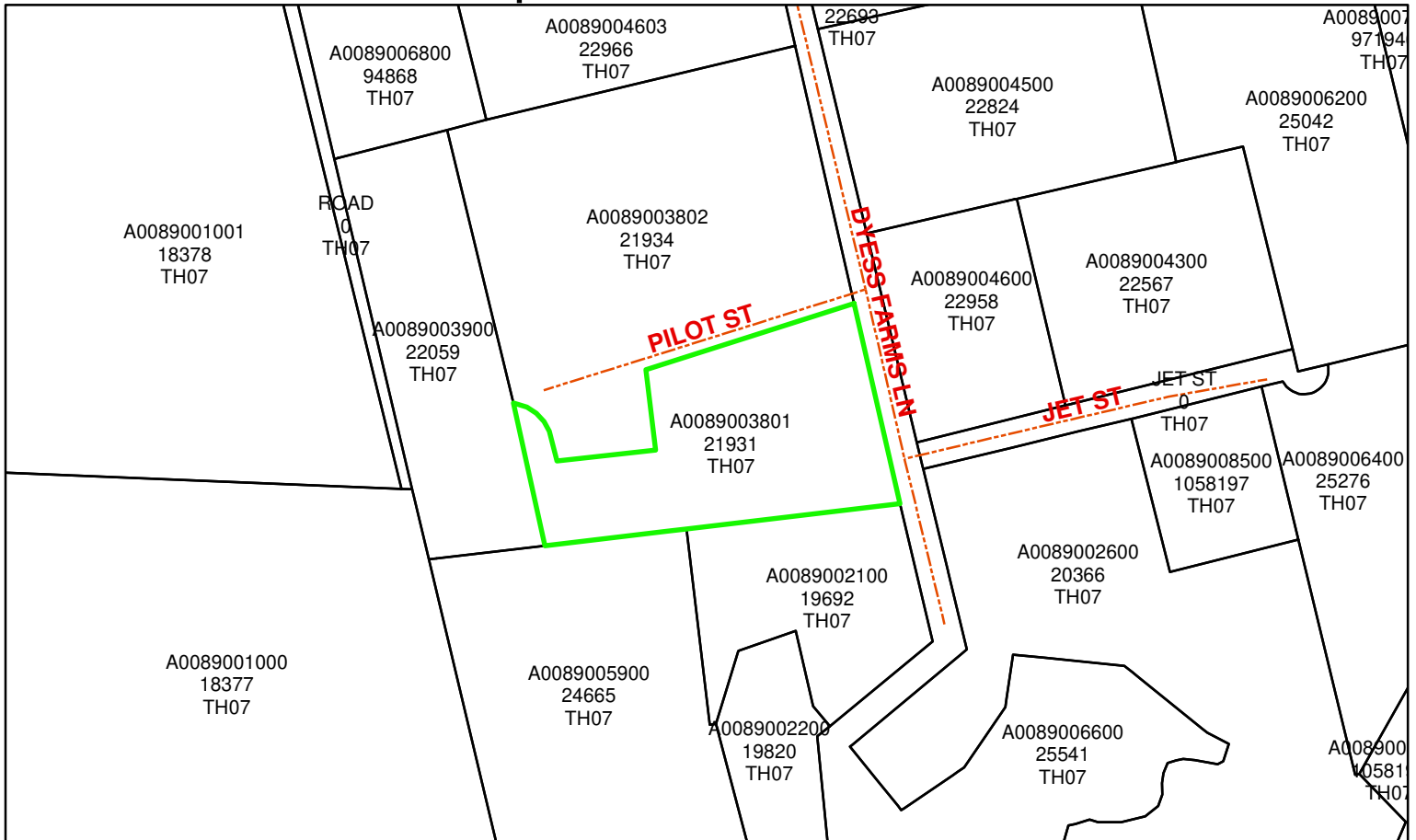

# Delinquent Sales Tax

## PropID:52989

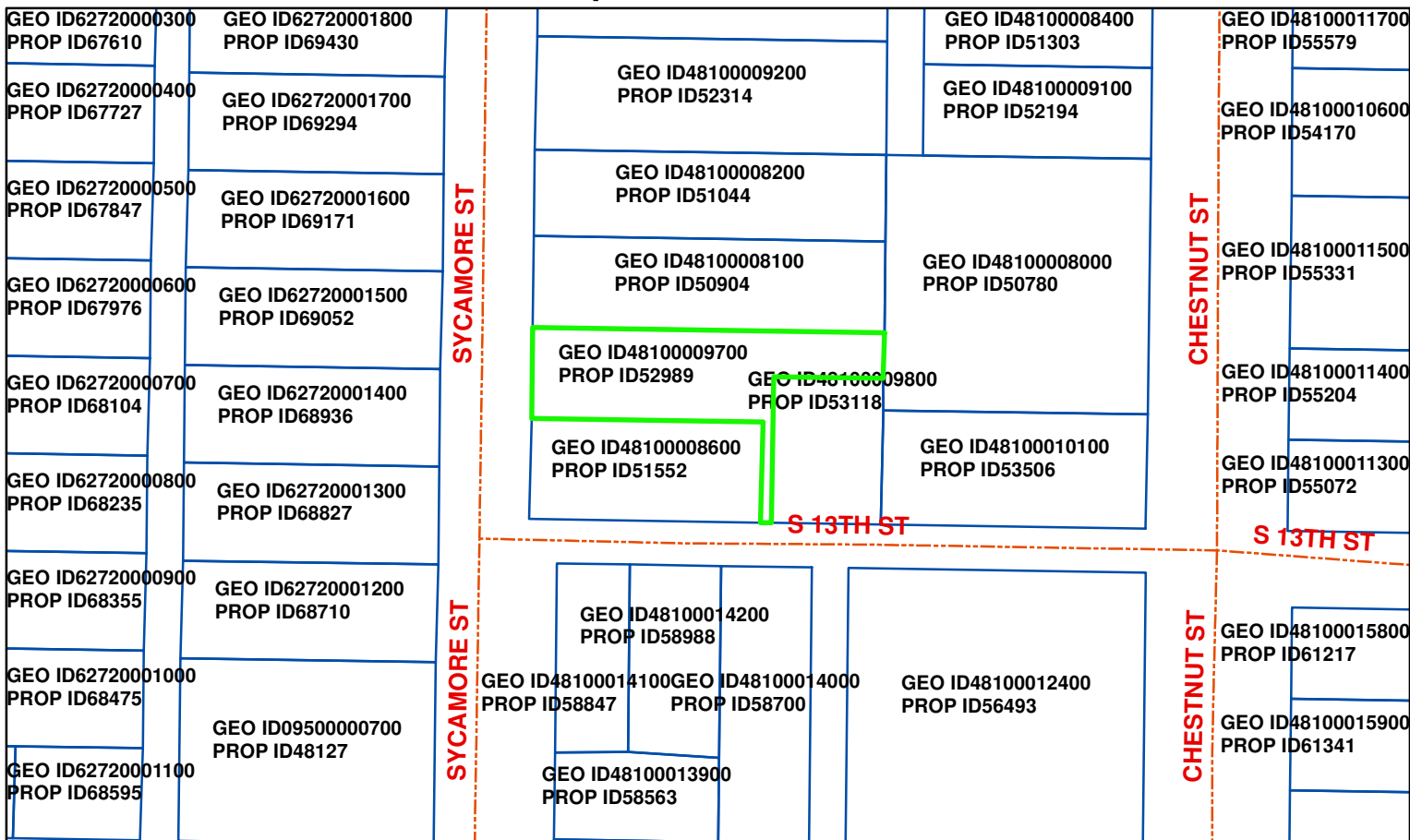

## PropID:62331

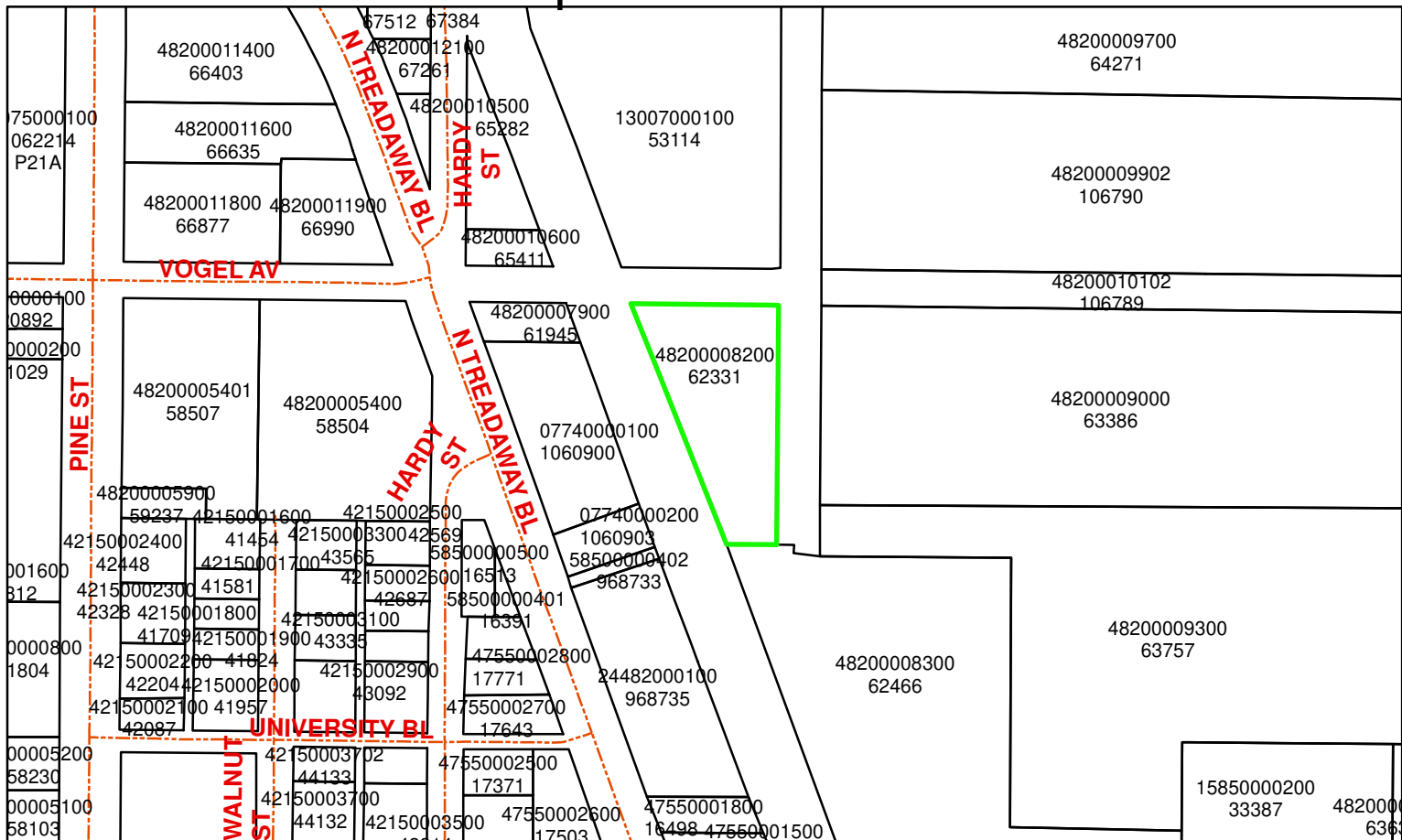

# Delinquent Sales Tax

## PropID:63108

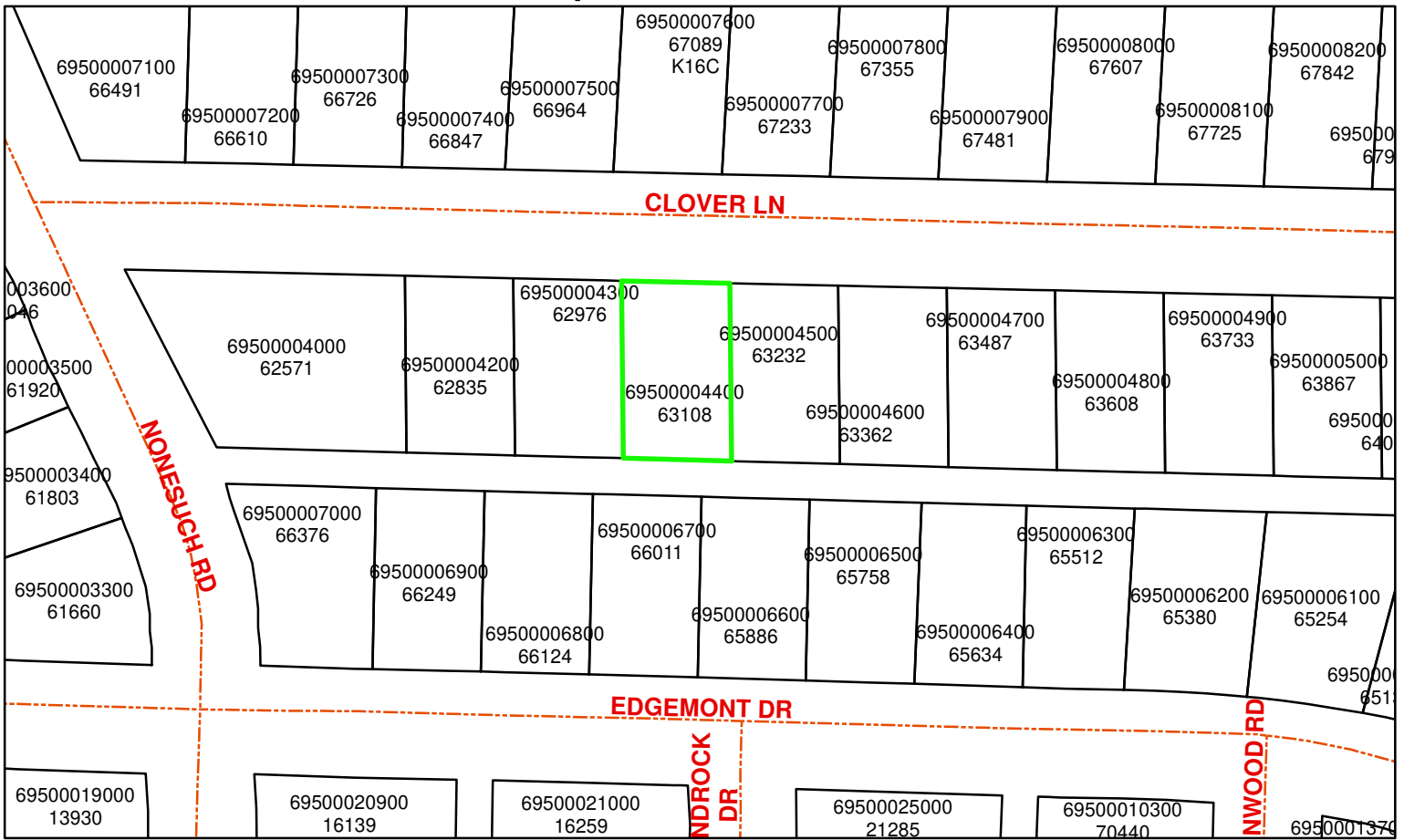

## PropID:17129

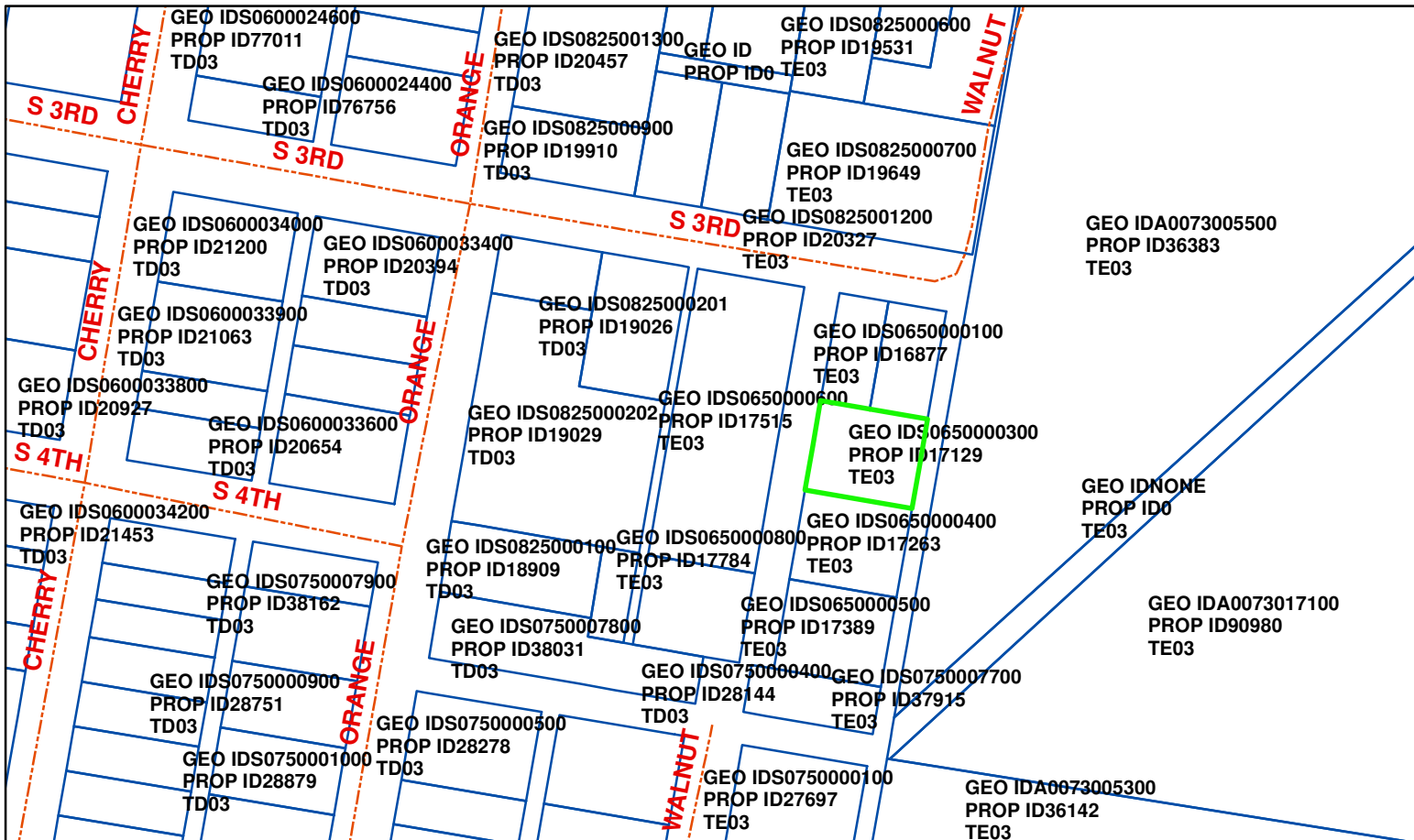

# Delinquent Sales Tax

## PropID:63217

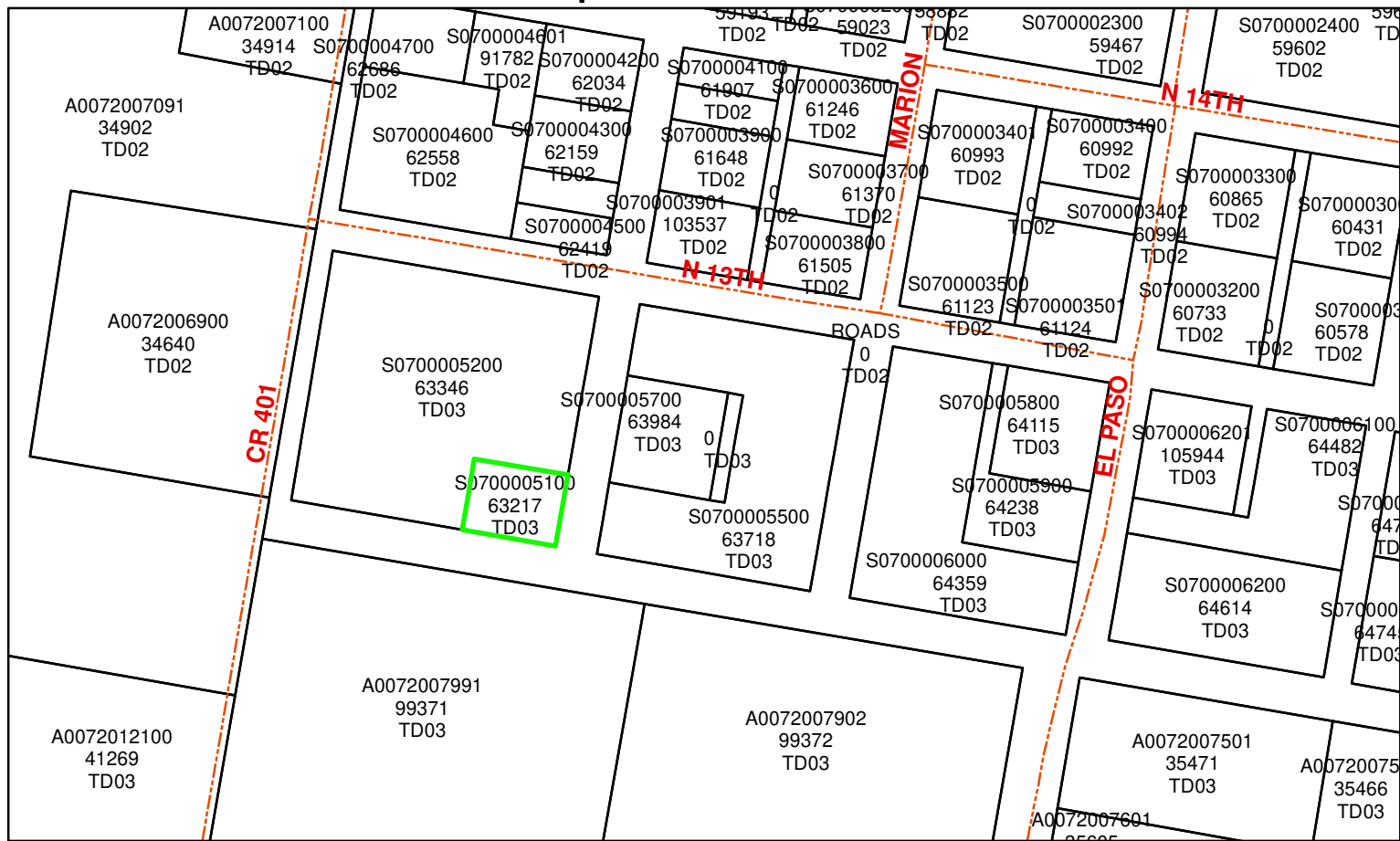

## PropID:49791

